



INSTALLATION MANUAL

Table of Content

1.DISCLAIMER OF LIABILITY	3
2.SAFETY PRECAUTIONS	3
3.UNPACKING AND STORAGE	4
3.1.PRODUCT IDENTIFICATION	5
3.2.ELECTRICAL RATING	5
4.ENVIRONMENTAL CONSIDERATIONS	29
4.1.CLIMATE CONDITIONS	29
5.SITE SELECTION	29
6.MOUNTING INSTRUCTIONS	30
6.1.MOUNTING METHODS	30
A.Mounting with Clamps	31
6.2.GROUNDING	32
6.3.MODULE WIRING	33
7.ELECTRICAL CONFIGURATION	34
7.1.FUSING	35
7.2.INVERTER SELECTION AND COMPATIBILITY	35
7.3.SELECTION FOR BLOCKING DIODE	35
7.4.BYPASS DIODE	36
8.MAINTENANCE AND CARE	36
9.WARNING	37
10.Contact information	37

1. DISCLAIMER OF LIABILITY

The installation, handling and use of Sunrev(YangZhou) Photovoltaic Crystalline modules are beyond company control. Sunrev(YangZhou) Photovoltaic does not assume any responsibility for loss, damage, injury or expense resulting from the improper installation, handling, use or maintenance.

Sunrev(YangZhou) Photovoltaic assumes no responsibility for any infringement of patents or other rights of third parties that may result from use of the module. No license is granted by implication or under any patent or patent rights.

Specifications are subject to change without prior notice.

2. SAFETY PRECAUTIONS

- Potentially lethal DC voltages can be generated whenever PV Modules are exposed to a light source therefore, avoid contact with electrically active parts and be sure to isolate live circuits before attempting to make or break any connections.
- Only authorized and trained personnel should have access or perform work on the modules or solar system.
- When working on electrical connections, remove all metallic jewelry, use properly insulated tools and wear appropriate personal protective equipment to reduce the risk of electric shock.
- Do NOT stand or step on, damage or scratch the front or backside surfaces of the module.
- Broken modules cannot be repaired and contact with any module surface or frame can lead to electrical shock. Do NOT use a module with broken glass or torn substrate.
- Do NOT disassemble the modules or remove any part of the module.
- Protect the electrical plug contacts against corrosion and soiling. Make sure that all connectors are corrosion free and clean before making the connection.
- Field-wiring connectors shall only be mated with connectors of the same manufacturer, type, and rating.
- Do NOT install or handle modules when they are wet or during periods of high wind.
- Ensure sure that all connections are securely made with no gap between the contacts. Any gap can result in electrical arcing that can cause a fire hazard and/or an electric shock.
- Make sure that the polarity of each module or a string is not reversed considering the rest of the modules or strings.
- Do NOT artificially concentrate sunlight on these solar modules.
- Sunrev(YangZhou) Photovoltaic modules are certified for operating in Class II installations at voltages below 1500Vdc. This maximum voltage should not be exceeded at any time and, as the voltage of the module increases, above data sheet values, at operating temperatures below 25°C,



then these need to be taken into account when designing a PV system.

- Do NOT use water to extinguish fires of an electrical origin.
- A photovoltaic module is likely to experience conditions that produce higher current and/or voltage than reported at standard test conditions. Factors to consider include module temperature and front side irradiance (and, for bifacial modules, ground or roof albedo, row spacing, and installation height). Accordingly, the values of V_{OC} and I_{SC} (or for bifacial modules, $I_{SC-ABSI}$) marked on this PV module should be multiplied by a factor of 1.25 when determining voltage and current ratings for components connected to the PV output.
- The safety factor of 1.25 given for the minimum voltage rating of the components in the example statement above may be modified during the design of a system according to the minimum temperature of the location of the installation and the temperature coefficient for V_{OC} . The safety factor of 1.25 given for conductor current ratings values for I_{SC} (or for bifacial modules, $I_{SC-ABSI}$) may be adjusted based on the maximum values of irradiance incident on the front side of the module (and the rear side for bifacial modules). To this purpose, a full simulation for the specific location and module orientation (and for bifacial modules, ground albedo, row spacing and installation height) is required. Further guidance for the choice of a safety factor other than 1.25 is given in IEC 62548.
- Artificially concentrated sunlight producing a PV module's current above the value reported on the nameplate shall not be directed onto the front side or the back side of the PV module.
- For bifacial modules, only front side (the side with higher maximum power measured at STC) is designed for prolonged exposure to direct sunlight.

3.UNPACKING AND STORAGE

- At time of receipt, verify that the product delivered is in fact the product ordered the product name, subname, and serial number of each laminate are clearly marked on the outside of each packing box.
- Leave the product in its original packing box until you are ready to install.
- Store packing boxes in a clean, dry area with relative humidity below 85% and ambient temperatures between -20°C and 40°C .
- Do NOT stack more than the maximum amount of allowable pallets on top of each other.
- At the installation site, take care to keep modules and particular their electrical contacts clean and dry before installation. If connector cables are left in damp conditions then the contacts may corrode. Any module with corroded contacts should not be used.
- If pallets are stored temporarily outside then place a protective covering over the pallet to protect it from direct weathering and do not stack more than one pallet high.

- Two people are required to unpack the modules from the packing box, when handling modules always use both hands.
- Do NOT use a knife to cut the zip-ties, but use wire cutting pliers.
- Do NOT place modules directly on top of each other.

PACKING LIST				
Product name	MODEL	320M-60D		
	N.W: 540KG	COLOR: White/White		
	G.W: 585KG	QTY: 30 PCS		
	SIZE: 1650*992*35mm	CELL:		
Pallet Number	PALLET NO:			
	Serial number			
	1	11	21	
	2	12	22	
	3	13	23	
	4	14	24	
	5	15	25	
	6	16	26	
	7	17	27	
	8	18	28	
	9	19	29	
	10	20	30	

Solar Module



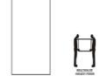

3.1. PRODUCT IDENTIFICATION

Each individual module has a unique serial number laminated behind the glass and another permanently attached to the back-sheet of the module. Note all serial numbers in an installation for your future records.

3.2. ELECTRICAL RATING

STC: 1000W/m², 25 ± 2°C, AM1.5

Module	SUN182THCD 450-54	SUN182THCD 490-60	SUN182THCD 495-60	SUN182THCD 500-60	SUN182THCD 580-72
Rated Voc at STC [V] / tolerance $\pm 3\%$	38.87	43.13	43.28	43.43	51.67
Rated Isc at STC [A] / tolerance $\pm 3\%$	14.57	14.53	14.61	14.69	14.37
Rated Vmp at STC [V]	32.47	35.72	35.87	36.03	42.69
Rated Imp at STC [A]	13.86	13.73	13.80	13.88	13.59
Rated Pmax at STC [W] / tolerance $\pm 3\%$	450	490	495	500	580
Bifaciality coefficient with tolerance	$\phi_{Isc} = 80\% \pm 5\%$, $\phi_{Voc} = 100\% \pm 5\%$, $\phi_{Pmax} = 80\% \pm 5\%$				
Rated Voc at BNPI [V] / tolerance $\pm 3\%$	38.87	43.13	43.28	43.43	51.67
Rated Isc at BNPI [A] / tolerance $\pm 3\%$	16.14	16.10	16.19	16.28	15.92
Rated Vmp at BNPI [V]	32.47	35.72	35.87	36.03	42.69
Rated Imp at BNPI [A]	15.37	15.21	15.28	15.38	15.07
Rated Pmax at BNPI [W] / tolerance $\pm 3\%$	499	543	548	554	643
Rated Isc at aBSI [A] / tolerance $\pm 3\%$	18.07	18.02	18.12	18.22	17.82
Maximum System Voltage [V]	1500	1500	1500	1500	1500
Maximum Over-Current Protection Rating [A]	30	30	30	30	30
Pmax Temperature Coefficients($W/^{\circ}C$)	-0.290 %	-0.290 %	-0.290 %	-0.290 %	-0.290 %
Voc Temperature Coefficients($V/^{\circ}C$)	-0.250 %	-0.250 %	-0.250 %	-0.250 %	-0.250 %
Isc Temperature Coefficients($A/^{\circ}C$)	+0.040 %	+0.040 %	+0.040 %	+0.040 %	+0.040 %

Min. creepage distance [mm]	12.73	12.9	12.9	12.9	12.7
-----------------------------	-------	------	------	------	------

Module	SUN182THCD 585-72	SUN182THCD 590-72	SUN210RTHCD 455-48	SUN210RTHCD 460-48	SUN210RTHCD 625-66
Rated Voc at STC [V] / tolerance $\pm 3\%$	51.76	51.85	35.86	36.06	49.28
Rated Isc at STC [A] / tolerance $\pm 3\%$	14.41	14.46	16.08	16.14	16.14
Rated Vmp at STC [V]	42.75	42.81	29.74	29.88	40.88
Rated Imp at STC [A]	13.68	13.78	15.30	15.40	15.29
Rated Pmax at STC [W] / tolerance $\pm 3\%$	585	590	455	460	625
Bifaciality coefficient with tolerance	$\phi_{Isc} = 80\% \pm 5\%$, $\phi_{Voc} = 100\% \pm 5\%$, $\phi_{Pmax} = 80\% \pm 5\%$				
Rated Voc at BNPI [V] / tolerance $\pm 3\%$	51.76	51.85	35.86	36.06	49.28
Rated Isc at BNPI [A] / tolerance $\pm 3\%$	15.97	16.02	17.82	17.88	17.88
Rated Vmp at BNPI [V]	42.75	42.81	29.74	29.88	40.88
Rated Imp at BNPI [A]	15.16	15.28	16.95	17.07	16.96
Rated Pmax at BNPI [W] / tolerance $\pm 3\%$	648	654	504	510	693
Rated Isc at aBSI [A] / tolerance $\pm 3\%$	17.87	17.93	19.94	20.01	20.01
Maximum System Voltage [V]	1500	1500	1500	1500	1500
Maximum Over-Current Protection Rating [A]	30	30	35	35	35
Pmax Temperature Coefficients($W/^{\circ}C$)	-0.290 %	-0.290 %	-0.290 %	-0.290 %	-0.290 %
Voc Temperature Coefficients($V/^{\circ}C$)	-0.250 %	-0.250 %	-0.250 %	-0.250 %	-0.250 %
Isc Temperature Coefficients($A/^{\circ}C$)	+0.040 %	+0.040 %	+0.040 %	+0.040 %	+0.040 %

Min. creepage distance [mm]	12.7	12.7	13.5	13.5	13.0
-----------------------------	------	------	------	------	------

Module	SUN210RTHC D630-66	SUN210THCD 710-66	SUN210THCD 715-66	SUN210THCD 720-66	
Rated Voc at STC [V] / tolerance $\pm 3\%$	49.48	48.50	48.70	48.90	
Rated Isc at STC [A] / tolerance $\pm 3\%$	16.20	18.60	18.66	18.72	
Rated Vmp at STC [V]	41.02	40.80	41.00	41.20	
Rated Imp at STC [A]	15.36	17.41	17.44	17.48	
Rated Pmax at STC [W] / tolerance $\pm 3\%$	630	710	715	720	
Bifaciality coefficient with tolerance	$\phi_{Isc} = 80\% \pm 5\%$, $\phi_{Voc} = 100\% \pm 5\%$, $\phi_{Pmax} = 80\% \pm 5\%$				
Rated Voc at BNPI [V] / tolerance $\pm 3\%$	49.48	48.50	48.70	48.90	
Rated Isc at BNPI [A] / tolerance $\pm 3\%$	17.95	20.61	20.68	20.74	
Rated Vmp at BNPI [V]	41.02	40.80	41.00	41.20	
Rated Imp at BNPI [A]	17.02	19.29	19.32	19.37	
Rated Pmax at BNPI [W] / tolerance $\pm 3\%$	698	787	792	798	
Rated Isc at aBSI [A] / tolerance $\pm 3\%$	20.09	23.06	23.14	23.21	
Maximum System Voltage [V]	1500	1500	1500	1500	
Maximum Over-Current Protection Rating [A]	35	35	35	35	
Pmax Temperature Coefficients($W/^{\circ}C$)	-0.290 %	-0.290 %	-0.290 %	-0.290 %	
Voc Temperature Coefficients($V/^{\circ}C$)	-0.250 %	-0.250 %	-0.250 %	-0.250 %	
Isc Temperature Coefficients($A/^{\circ}C$)	+0.040 %	+0.040 %	+0.040 %	+0.040 %	

Min. creepage distance [mm]	13.0	13.0	13.0	13.0	
-----------------------------	------	------	------	------	--

4. ENVIRONMENTAL CONSIDERATIONS

4.1. CLIMATE CONDITIONS

Sunrev(YangZhou) Photovoltaic Crystalline series modules may be installed in the following conditions for more than 25 years. In addition to the required IEC certification to meet European standards Sunrev(YangZhou) Photovoltaic products have also been tested to verify resistance to ammonia fumes that may be present around barns sheltering cattle, as well as suitability for installation in humid (coastal) areas and areas of high sand storms.

Environment

- Ambient temperature: -40°C to +40°C.
- Operating temperature: -40°C to +70°C.
- Storage temperature: -20°C to +50°C.
- Humidity: < 85RH%
- Mechanical Load Pressure*: The design pressure is 3600 (downward)/1600 (upward) and the safety factor is 1.5

It is possible that modules installed with restricted airflow are not allowed for use in some hot locations, depending on system design parameters. Installers should assess if the system design at a specific geographic location will result in a 98th percentile module operating temperature greater than 70 °C (80 °C or 90 °C if tested to Level 1 or Level 2 conditions), and must consider these factors in design of systems (refer to IEC TS 63126 for more information)

*Notes:

- The mechanical load bearing is dependent upon the mounting methods used and failure to follow the instructions of this manual may result in different capabilities to withstand snow and wind loads. The system installer must ensure that the installation methods used meet these requirements and any local codes and regulations.

5. SITE SELECTION

- Sunrev(YangZhou) Photovoltaic Modules can be mounted in landscape and portrait orientation however the impact of dirt shading the solar cells can be minimized by orienting the product in portrait.
- For optimum energy production, solar modules should normally be mounted facing the equator

at an angle to the horizontal plane equivalent to the latitude of the installation. In the event that you mount the solar modules at a different angle or orientation then the annual energy production may potentially be adversely impacted.

- When installing solar modules on a roof always leave a safe working area between the edge of the roof and the external edge of the solar array.
- Position the modules to minimize the chances of shading at any time of the day. Shading can normally be minimized by ensuring that the distance between the obstruction and solar array is greater than three times the obstruction's height.
- In order not to affect the fire rating, installation angle must be less than 5 in/ft, Fire rating of Sunrev(YangZhou) Photovoltaic modules is Class C according to UL790.

which is the most severe condition. And there is no limited for title angel . When installing Solar modules on a roof, the roof must be covered with a layer of fireproof material applicable to this class, and adequate ventilation must be ensured between the back of the module and the installation surface. A safe working area also must be left between the edge of the roof and the external edge of the Solar array.

When the Modules are supported parallel to the surface of the building wall or roof, a minimum stand-off of 102 mm (4 inches) between the modules and the surface of the wall or the roof is required to allow air to circulate behind the Modules for heat dissipation.

- Avoid using a mounting method that will block the drainage holes in the module frame.
- When all solar modules are mounted in the same plane and orientation then all can be expected to have similar performance throughout the day and can be connected together to the same inverter channel.
- If solar modules on the same installation are mounted at different angles or orientations then energy production can normally be optimized by connecting the different orientations to different inverters (or different MPPT if the inverter has more than one MPPT). Refer to inverter manufacturers for further guidelines.
- Do not install modules in a location where they will be immersed in or continually exposed to water.
- Sunrev(YangZhou) Photovoltaic Modules application altitude: <2000m.

6.MOUNTING INSTRUCTIONS

6.1. MOUNTING METHODS

PV modules can be mounted to the substructure using specially designed module clamps.

Regardless of the fixing method the final installation of the modules must ensure that:

A clearance of at least 115mm is provided between modules frame and the surface of the wall or roof.

The minimum distance between two modules is 10 mm.

The mounting method does not block the module drainage holes.

Panels are not subjected to wind or snow loads exceeding the maximum permissible loads, and are not subject to excessive forces due to the thermal expansion of the support structures.

A. Mounting with Clamps:

- Sunrev(YangZhou) Photovoltaic has tested its modules with a number of clamps from different manufacturers and recommends the use of clamps which have an EPDM or similar insulating washer, fixing bolt of at least M6. The clamp must overlap the module frame by at least 7mm but no more than 10 mm.
- Use at minimum 4 clamps to fix modules on the mounting rails.
- Modules clamps should not come into contact with the front glass and must not deform the frame.
- Be sure to avoid shadowing effects from the module clamps.
- The module frame is not to be modified under any circumstances.
- When choosing this type of clamp-mounting method, use at least four clamps on each module, two clamps should be attached on each long sides of the module (for portrait orientation) and each short sides of the module (for landscape orientation). Depending on local wind and snow loads, additional clamps may be required to ensure that modules can bear the load.
- Applied torque should refer to mechanical design standard according to the bolt customer is using, ex:M6 is 8N*M;M8 is 16N*M.

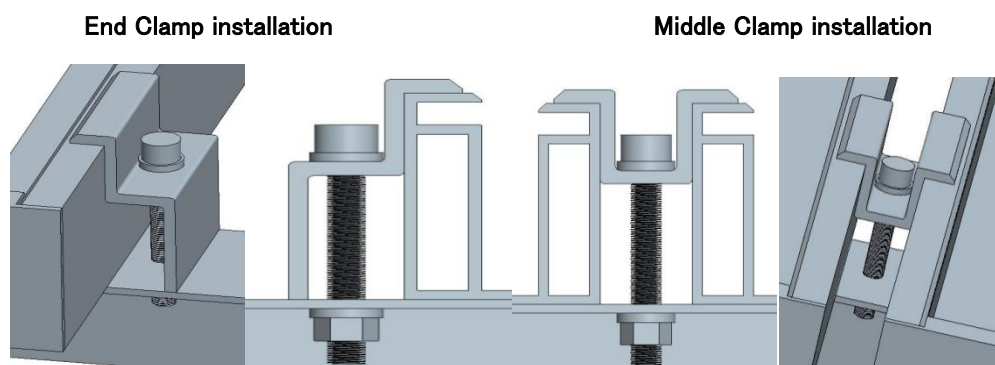
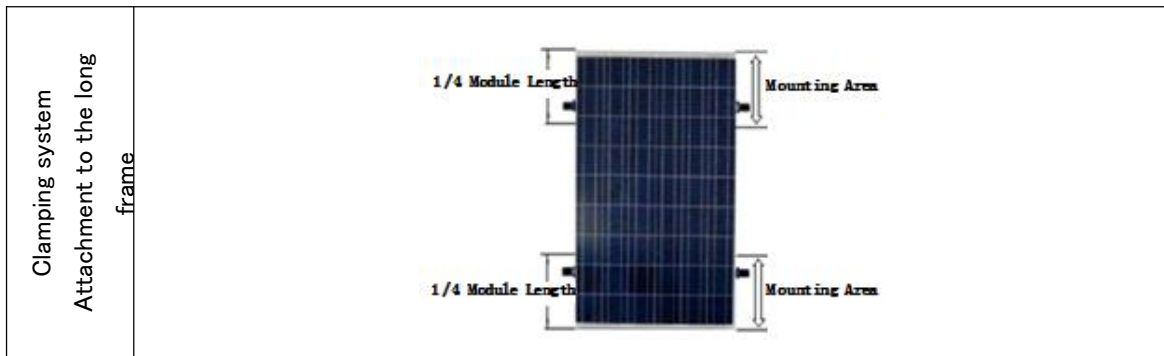

Figure1. Module installed with clamp fitting method

	<p>Design Load: 1600Pa Safety Factors: 1.5(upward)</p>	<p>Design Load: 3600Pa Safety Factors: 1.5(downward)</p>
--	--	--



Other mounting configurations can be used however, failure to comply with the above recommendations will result in a lowering of the load handling capabilities below the product specification 5400/2400Pa and product failure as a result of an overload situation will not be covered by the guarantee.

B. Fasten with bolts:

- Mount the module to the bracket rail using corrosion-resistant bolts, elastic washers, and flat washers. The torque used should be large enough to allow the module to be securely fastened. If a special bracket system or special mounting method is required, please reconfirm the torque value with the bracket supplier. The installation method is shown in the figure.
- See Figure 3 for details of the product type and mounting position of modules with bolt mounting (inner 4 holes), and Figure 2 for details of the product type and mounting position of components with bolt mounting (outer 4 holes).
- The frame of each module has 8- $\phi 9 \times 14$ mm and 6- $\phi 7 \times 10$ mm mounting holes, ideally placed to optimize the load handling capability and to secure supporting structure of the modules.
- Secure the module in each fixed position with M8 bolts and flat washers, spring washers and nuts as shown in Figure 1 and tighten to a torque of 16 to 20 N·m. The torque reference value of M6 bolts is 9~12 N·m.
- All parts in contact with the frame should use flat stainless steel washers of minimum 1.8 mm thickness with an outer diameter of 20-24 mm.

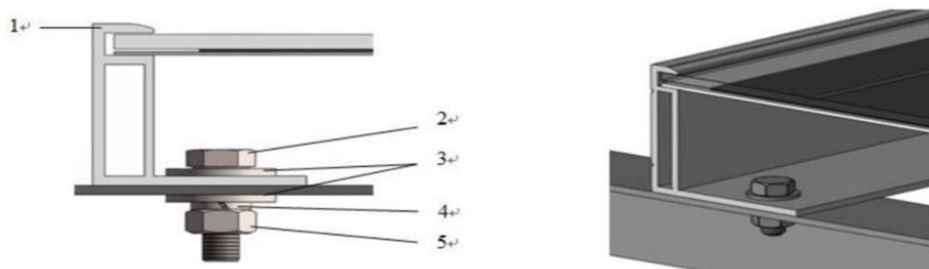

Figure 2. Bolt Installation Diagram

- | | | |
|--------------------------|----------------------------|----------------------|
| 1) Aluminum Frame | 2) M8 Stainless Bolt | |
| 3) Flat Stainless Washer | 4) Spring Stainless Washer | 5) HEX Stainless Nut |

Mounting Hole (mm)	Recommended Bolt Size
--------------------	-----------------------

14 x 9	M8
10 x 7	M6

	Design Load: 1600Pa Safety Factors: 1.5(upward)	Design Load: 3600Pa Safety Factors: 1.5(downward)
Clamping system Attachment to the long frame		

Figure 3. Installation method of bolts (inner 4 holes)

6.2. GROUNDING

- All module frames and mounting racks must be properly grounded in accordance with appropriate respective National Electrical Code.
- Proper grounding is achieved by bonding the module frame(s) and all metallic structural members together continuously using a suitable grounding conductor. The grounding conductor or strap may be copper, copper alloy, or any other material acceptable for use as an electrical conductor per respective National Electrical Codes. The grounding conductor must then make a connection to earth using a suitable earth ground electrode.
- Sunrev(YangZhou) Photovoltaic modules can be installed with the use of third party listed grounding devices for grounding the metallic frames of PV modules. The devices have to be installed in accordance with the grounding device manufacturer’s specified instructions.
- Sunrev(YangZhou) Photovoltaic recommends using the following grounding ways:
 - a) Using Schleiter for grounding. Connecting modules to the support structure according to the

picture below. (Grounding accessories need pass the UL467 standard test.)

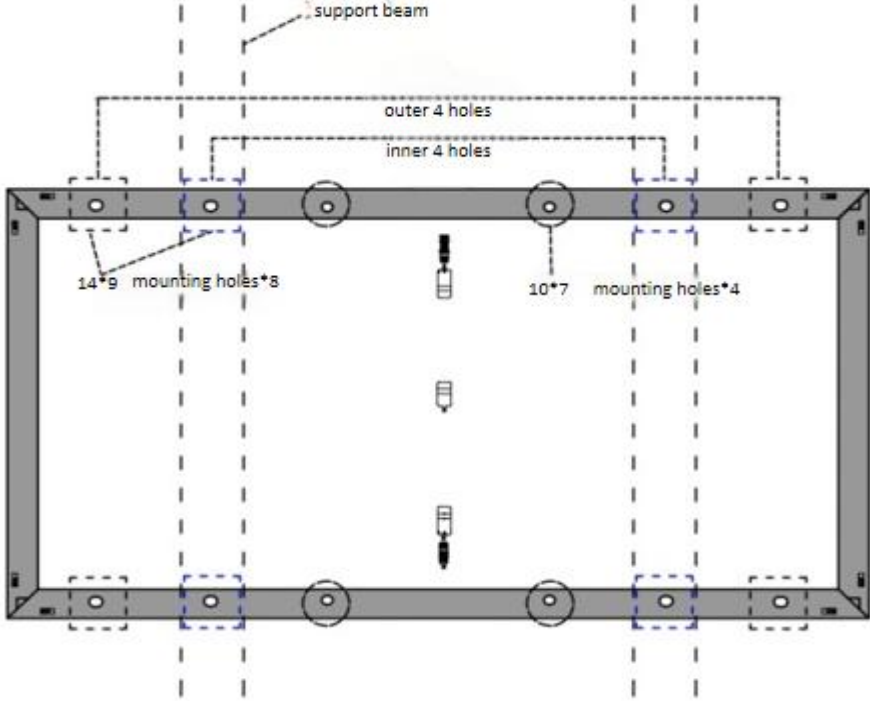
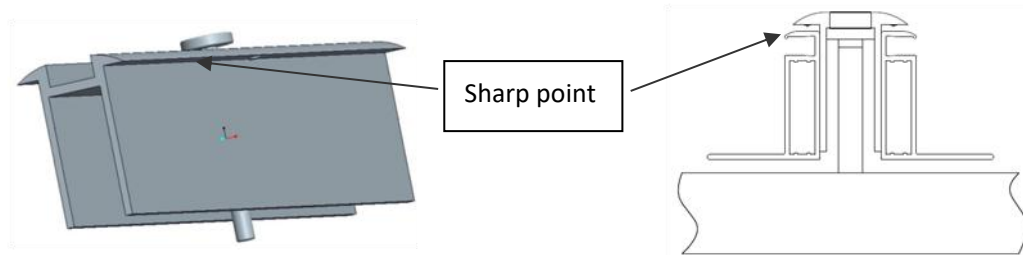

- Recommended torque is 20.5Nm
- For more information, please contact the supplier Schletter (<http://www.solar.schletter.de>)
- b) The traditional way of grounding (Grounding accessories need pass the UL467 standard test and UL E34440/E6207 test.)

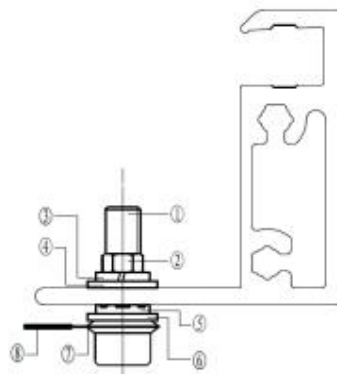

- ① Stainless steel bolt M4 × 30
- ② Stainless steel nut M4
- ③ Stainless steel spring washer M4
- ④ ⑥ Stainless steel flat washer M4
- ⑤ Stainless steel lock-toothed washer M4
- ⑦ Stainless steel cup washer M4
- ⑧ Grounding wire

- For fully grounding, grounding hardware should penetrate the anodic oxidation layer of frame.
- Recommended 10-12 AWG bare copper grounding wire.

6.3. MODULE WIRING

- All wiring should be performed, by qualified installers, in accordance with the local codes and regulations.
- Modules can be connected in series to increase the operating voltage by plugging the positive plug of one module into the negative socket of the next. Before connecting modules always ensure that the contacts are corrosion free, clean and dry.
- Product can be irreparably damaged if an array string is connected in reverse polarity to another.

Always verify the voltage and polarity of each individual string before making a parallel

- connection. If you measure a reversed polarity or a difference of more than 10V between strings then check the string configuration before making the connection.
- Sunrev(YangZhou) Photovoltaic modules are provided with stranded copper cables with a cross sectional area of 4mm² which are rated for 1500V dc, 90°C and are UV resistant. All other cables

used to connect the DC system should have a similar (or better) specification. Sunrev(YangZhou) Photovoltaic recommend that all cables are run in appropriate conduits and sited away from areas prone to water collection.

- The maximum voltage of the system must be less than the maximum certified voltage (1500V typically) and the maximum input voltage of the inverter and of the other electrical devices installed in the system. To ensure that this is the case, the open circuit voltage of the array string needs to be calculated at the lowest expected ambient temperature for the location. This can be done using the following formula.

$$\text{System voltage} = N \times \text{Voc} \times \{1 + \text{TCvoc} \times (25 - \text{Tmin})\}$$

Reverse current overload rating: the Maximum Over-Current Protection Rating of each PV Module \times 1.35

*Notes:

N: No modules in series

Voc: Open circuit voltage of each module (refer to product label or data sheet)

TCvoc: Thermal coefficient of open circuit voltage for the module (refer to table (add))

Tmin: Minimum ambient temperature

- The minimum and maximum outer diameters of the cable are 5 to 7mm².
- For field connections, use at least 4 mm² copper wires insulated for a minimum of 90°C and sunlight resistance with insulation designated as PV Wire.
- The minimum bending radius cables should be 43mm.



7.ELECTRICAL CONFIGURATION

Photovoltaic (electric) systems operate automatically and require very little day-to-day supervision. The solar array generates DC electricity whenever light falls on it similarly the inverter automatically turns ON as soon as there is sufficient energy from the solar array to efficiently convert this into grid quality AC power.

*Caution:

- The module is rated to operate at potentially lethal DC voltages which have the potential can cause severe electrical shock, arcing and fire hazards. Whilst some solar modules, manufactured by Sunrev(YangZhou) Photovoltaic, are certified to operate up to 1500V always check the module label to confirm the actual rating of your product before making connections.

Always use a suitably rated isolator (DC switch) to interrupt the current flow before disconnecting the connectors. The connector should be mated with its original female or male connector of the same supplier.

Zerun Co., Ltd. Type: Z4S-abcd, DC 1500V, 41A, IP68(1m,1h), -40°C to 85°C

Taizhou Chuangda Electronic Co., Ltd. Type: PV-TT02, CD2, DC 1500V, 43A for PV-TT02, 41A or 48A for CD2, IP68(1m,1h), -40 °C to 85 °C

Zhejiang Minghe New Energy Technology Co., Ltd. Type: PV-MH5, DC 1500V, 41A, IP68(1m,1h), -40°C to 85°C

7.1.FUSING

When fuses are fitted they should be rated for the maximum DC voltage and connected in each, non-grounded pole of the array (i.e. if the system is not grounded then fuses should be connected in both the positive and negative poles).

The maximum rating of a fuse connected in series with an array string is typically 20A /25A/30A/35A, but the actual module specific rating can be found on the product label and in the product datasheet. This fuse rating value also corresponds to the maximum reverse current that a module can withstand (when one string is shaded then the other parallel strings of modules will be loaded by the shaded string and current will flow) and therefore impacts the number of strings in parallel. Parallel module configurations: fuse rating/Isc.for bifacial modules, Isc-aBSI.

7.2. INVERTER SELECTION AND COMPATIBILITY

When installed in systems governed by IEC regulations, Sunrev(YangZhou) Photovoltaic modules normally do not need to be electronically connected to earth and therefore can be operated together with either galvanically isolated (with transformer) and transformer less inverters.

Potential Induced Degradation (PID) is sometimes observed in PV modules due to a combination of high humidity, high temperature and high voltage. PID is most likely to cause degradation under the following conditions:

- a) Installations in the warm and humid climates
- b) Installation close to a source of continual moisture, such as bodies of water

To reduce the risk of PID, we strongly suggest that modules feature Sunrev(YangZhou) Photovoltaic 's Anti-PID technology, which can be applied to any Sunrev(YangZhou) Photovoltaic product.

Alternatively, we recommend the use of an inverter that includes a transformer as well as proper grounding of the negative DC leg of the PV array.

Choose inverters with isolation transformers in hot and wet areas (such as shores, wetlands), to ensure proper module function under positive voltage.

7.3. BLOCKING DIODE

In a system that uses a battery, blocking diodes are typically placed between the battery and the module output to prevent battery discharge at night and rainy weather.

Diodes that are used as blocking diodes must have a:

- a) Rated Average Forward Current [$I_{F(AV)}$] above the maximum system current at the highest module operating temperature.
- b) Rated Repetitive Peak Reverse Voltage [V_{RRM}] above the maximum system voltage [V_{max}] at the lowest module operating temperature (IEC: $V_{max}=1500V$;).

7.4. BYPASS DIODE

Partial shading of an individual module can cause a reverse voltage across the shaded module. Current is then forced go through the shaded area by the other modules. When a bypass diode is wired in parallel with the series string, the forced current will flow through the diode and bypass the shaded module, thereby minimizing module heating and array current losses.

Schottky, Type: ZERUN 40SQ045(30A), Schottky, Type: ZERUN 35SQ045 (25A),

used in junction box type Z8-abcd, DC1500V(d=O), 25A(c=P),30A(c=N), -40 to 85°C, IP68(1m,1h)

Schottky, Type: Zhongchao/Hornby MK6045(30A), Schottky, Type: Zhongchao/Hornby MK5045(25A),

used in junction box type PV-ZC003, DC1500V, 25A(MK5045),30A(MK6045), -40 to 85°C, IP68(1m,1h)

Schottky, Type: Yangjie 40SQ045(30A), Schottky, Type: Yangjie 30SQ045-SL(25A),

used in junction box type MH2z, DC1500V, 25A(z=3 or 3B),30A(z=4 or 4B), -40 to 85°C, IP68(1m,1h)

8.MAINTENANCE AND CARE

A well designed solar system requires minimal maintenance; however, system performance and reliability can be improved by taking some simple steps.

- Maintenance should be carried out at least once a year by trained personnel.
- Trim any vegetation which may shade the solar array thus impacting performance.
- Check that mounting hardware is properly tightened.
- Inspect all cables to verify that connections are tight; the cables are protected from direct sunlight and sited away from areas of water collection.
- Check that all string fuses in each non/earthed pole are operating.
- In the event that the solar modules need to be cleaned then clean the module use a soft cloth together with a mild detergent and clean water. Take care to avoid severe thermal shocks which might damage the module by cleaning modules with water which has a similar temperature to the modules being cleaned.
- On large systems, the benefit of cleaning dirt and debris from the array is a trade-off between the cost of the cleaning, increased energy production as a result of this cleaning, and the time for the re-soiling of the modules after cleaning.

- If you are unsure whether the array or section thereof needs to be cleaned then first select an array string that is particularly soiled then
 - Measure & record the inverter feed in current from that string
 - Clean all modules in the string
 - Measure the inverter feed in current again and calculate the % improvement from cleaning
 - If the improvement is less than 5% then it is normally not worth spending the expense on cleaning
- The above verification should only be carried out when the insolation is effectively constant (clear sky, strong sunshine, no clouds)
- The back surface of the module normally does not need to be cleaned but, in the event this is deemed necessary, avoid the use of any sharp projects that might damage the penetrating the substrate material.

9.WARNING

These solar modules do not contain any user serviceable parts,

If you suspect that your installation is not working properly, then contact your installer immediately.

- 1、 Contact your installer
- 2、 Contact Sunrev(YangZhou) Photovoltaic after sales service team at:www.sunrev.com.cn

WARNING: For any electrical maintenance, the PV system must first be shut down. Improper maintenance can cause lethal electric shock and/or burns.

10.Contact information

Sunrev(YangZhou) Photovoltaic Technology Co., Ltd
No.118, Jingang Road, Yangzhou Economic and
Technological Development Zone 225100 Yangzhou City,
Jiangsu Province, PEOPLE'S REPUBLIC OF CHINA

Tel: +86-0514-80351508